

ISO-LOCK HYDRAULIC PIN GRABBER

Introducing
our new
**ISO-LOCK
HYDRAULIC
PIN GRABBER**



KEY FEATURES



SAFETY ISO-LOCK

Your fail-safe guardian—keeps buckets and attachments secure, even when things go wrong.

2

· YEAR ·
WARRANTY



INTERNAL SPRING-POWERED

Keeps the piston rod extended, activating the grab hook and safety latch if pressure fails.

FAIL-SAFE POWER

Our counterbalance valve locks oil in the cylinder, keeping attachments secure even if hydraulic pressure fails.

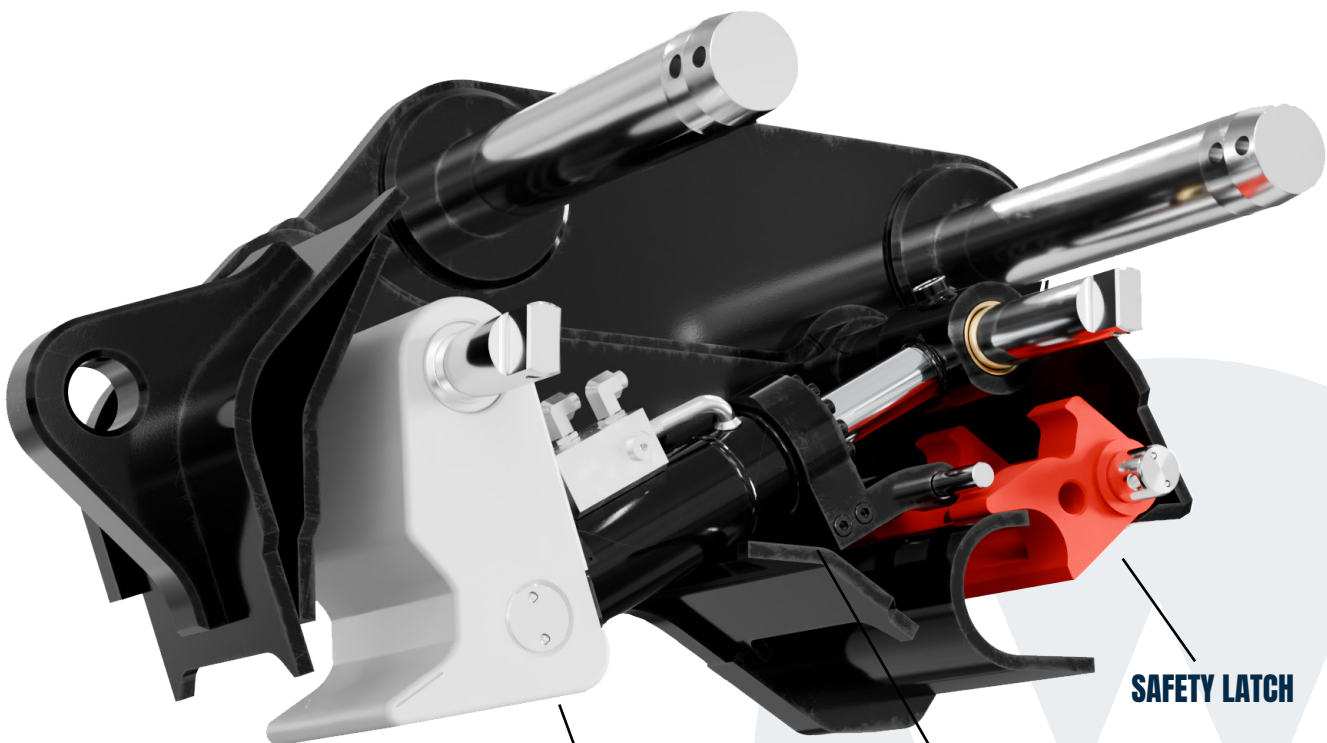
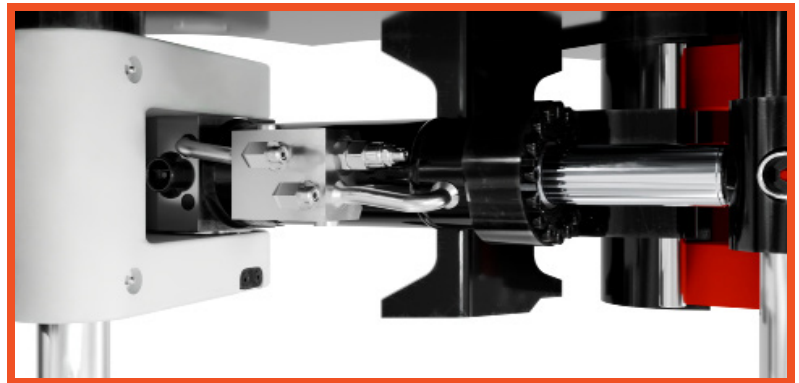

GRAB HOOK

HYDRAULIC CYLINDER

SAFETY LATCH





Series	200	250	300
Part Number	101281	103212	103224
Weight	327-kg / 721-lb	440-kg / 970-lb	494-kg / 1,089-lb
Lifting Capacity	10-MT / 22,046-lb	14-MT / 30,864-lb	19-MT / 41,887-lb
Machine	ZX190LC/ZX210LC /ZX245USLC	ZX250LC/ZX290LC/Z X300LC/ZX345USLC	ZX350LC/ZX380LC

